

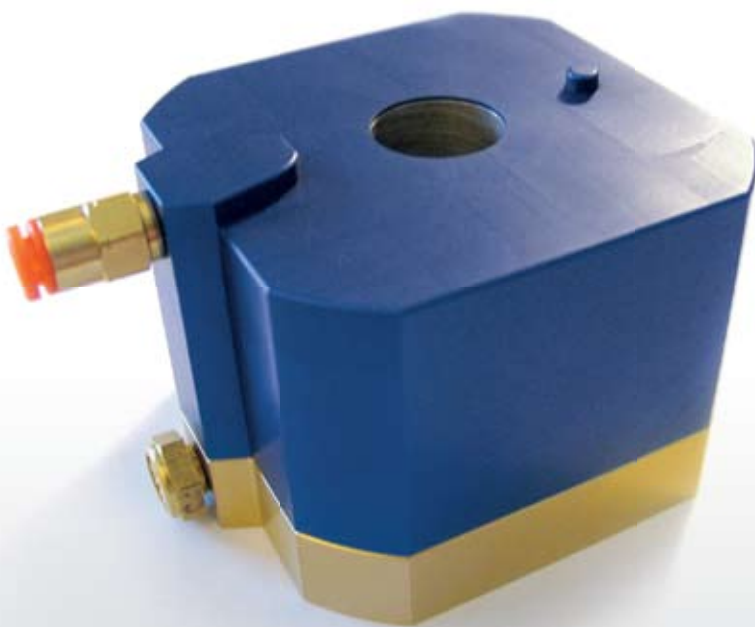

DON'T RECOIL.



UNCOIL

WITH THE ONLY AIRTIGHT
SOLUTION TO VALVE PERFORMANCE.

PNEUMAGNETIC... THE UNCOIL.

Pneu **Magnetic**

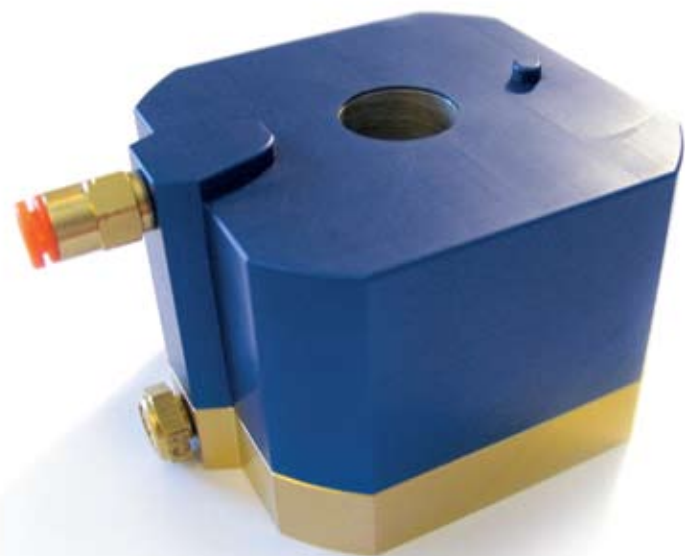

THE PNEUMAGNETIC ACTUATOR
PNEUMATIC NEODYMIUM REPLACEMENT FOR OEM COILS.
[U.S. PATENT NO. 6,991,221]

SO SIMPLE IT'S A
BREATH OF FRESH AIR.

THE PNEUMAGNETIC
ACTUATOR REPLACES
THE STANDARD
ELECTRIC COIL ON
YOUR SOLENOID VALVE
TO PROVIDE *SIMPLE,*
RELIABLE, SAFE VALVE
PERFORMANCE.

CONTENTS

2-3 › COST ANALYSIS

4-5 › OLD WAY v. UNCOILED WAY

6-7 › PNEUMAGNETIC TECHNOLOGY

8-9 › TECHNICAL SPECS

THE PNEUMAGNETIC SOLUTION DELIVERS THE LOWEST INSTALLED COST

NO ELECTRICITY > NO WIRING > NO CONDUIT > NO BARRIERS

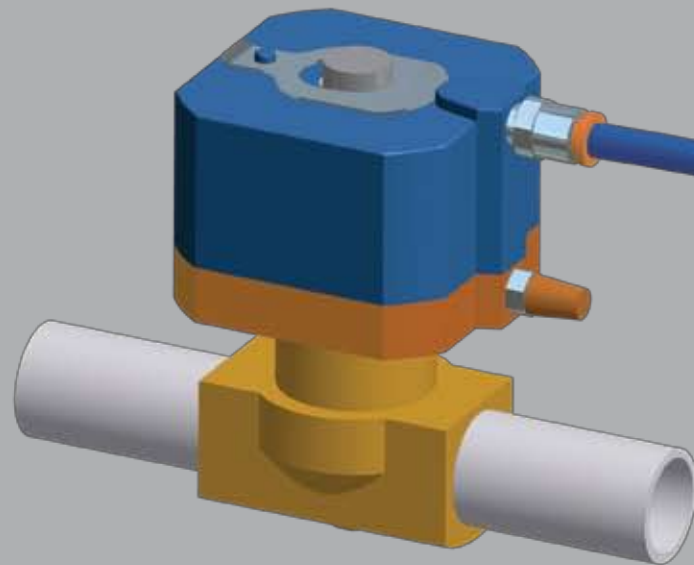

LOWEST INSTALLED COST SOLUTION

- > One simple plastic tube. One simple pilot valve.
- > Fewest number of components, least amount of labor, space and time to install.
- > Total system is as simple as non-hazardous installations... *because it is!*
- > Easiest system to maintain & modify.

HOW TO CONVERT YOUR VALVE

Simply remove the OEM coil and slip on the PneuMagnetic actuator; run pneumatic tubing to a small pilot valve installed with your control system.

FEATURES AND BENEFITS

- > Safe, non-electric
- > Uses standard hermetically sealed valves
- > Does not require valves with a system fluid seal
- > Lowest installed cost
- > Requires less space than traditional solutions
- > Easier to maintain, does not require special skills
- > Less clutter in and around your equipment and in the plant
- > Extremely high service life
- > No coil hum or heating
- > No conduit means increased flexibility for future plant layout modifications
- > Operating pressures from 20–125 psi
- > Retrofit existing electrical systems using existing valves without breaking into the valve fluid circuit

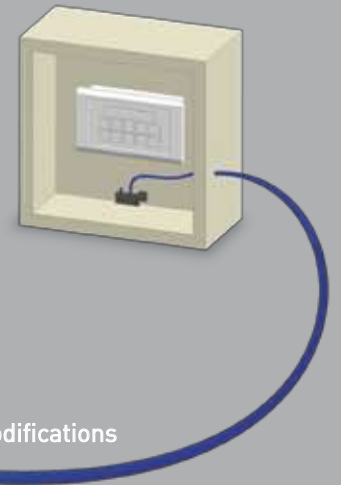

ELIMINATE TRADITIONAL HIGH COST APPROACHES

Traditional electric installations require extensive material, labor, space, and time to install.

Solenoid valves require wiring and conduit installations that meet national and local codes. In hazardous installations these requirements can be several times the cost of the valve.

Valve cost is a small fraction of the *Total Installed Cost*.

EXPLOSION PROOF APPROACH: HIGH INSTALLED COST

- > Requires Rigid Conduit PLUS Spark Arrestor PLUS Explosion Proof Conduit Box.
- > Results in a high cost system: difficult to install, repair and maintain system safety.

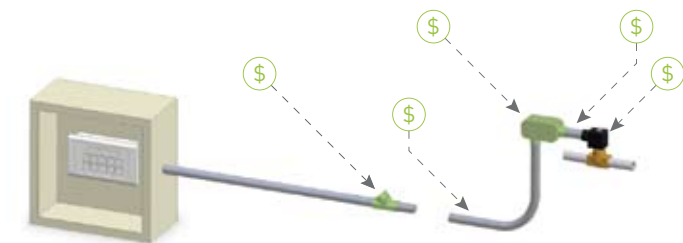

INTRINSIC BARRIER APPROACH: HIGH INSTALLED COST

- > Requires Expensive IS Barrier PLUS Strict Space, Wiring and Enclosure Requirements.
- > Results in a high cost system: difficult to install, repair and maintain system safety.

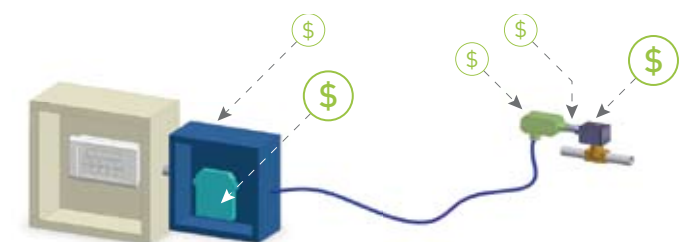

SIMPLIFY

REPLACE THIS



WITH THIS

CONDUIT INSTALLATION
MATERIAL & LABOR COSTS



SIMPLE, FLEXIBLE,
INEXPENSIVE PNEUMATIC
TUBING CONNECTION

CONDUIT SPACE



NOTHING!

RIGID CONNECTION TO VALVE
 > DIFFICULT TO INSTALL
 > DIFFICULT TO TEST
 > DIFFICULT TO MAINTAIN



FLEXIBLE CONNECTION
FOR SIMPLE
INSTALLATION, TESTING
& MAINTENANCE

SPARK ARRESTORS



NOTHING!

CONDUIT BOXES



NOTHING!

POTENTIAL ELECTRIC
HAZARD



NO ELECTRIC HAZARD

ELECTRIC
CODE REQUIREMENTS



SIMPLE, SAFE,
PLANT AIR

SYSTEM SAFETY CAN
BE COMPROMISED DURING
MAINTENANCE & REPAIR



STAYS SAFE
EVEN DURING VALVE
MAINTENANCE

THE DIFFERENCE IS IN THE DETAILS.

PNEUMAGNETIC... BEYOND OLD PNEUMATICS.

The PneuMagnetic solution uses the reliable, hermetically sealed direct acting valves you've learned to trust. Why use direct acting valves? > *No leaky process fluid seals.*

> *Total adaptability.* > *Wider range of valves from which to choose.*

THE OLD WAY

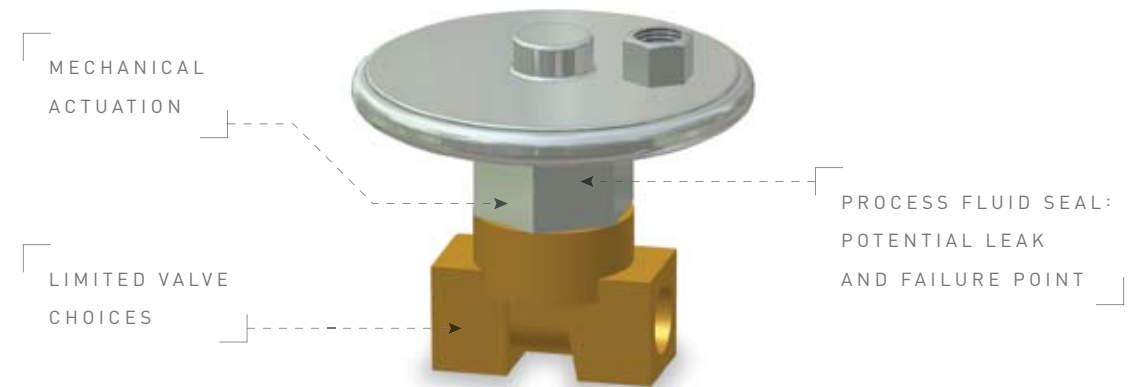

THE UNCOILED WAY

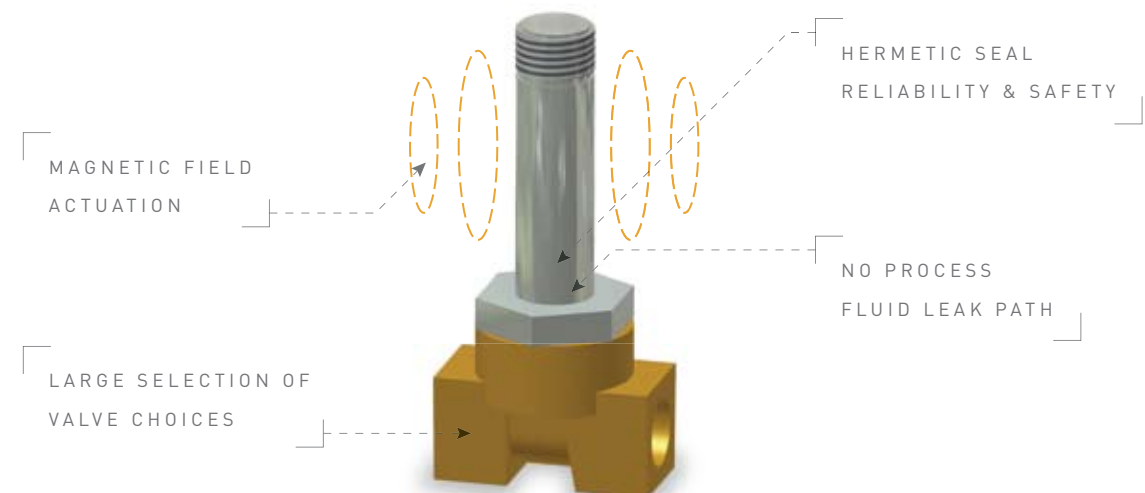

PNEUMAGNETIC TECHNOLOGY

[U.S. PATENT NO. 6,991,221 — INT'L PATENTS PENDING]

SHORT STROKE / LOW VOLUME PNEUMATIC CHAMBER FOR FAST RESPONSE & LOW AIR CONSUMPTION

POWERFUL PNEUMAGNETIC "FOCUSED FIELD" MAGNET ASSEMBLY

EASY INSTALLATION & REMOVAL SIMPLIFIES MAINTENANCE & TESTING

EASY ON / EASY OFF

PERMANENTLY SEALED BORE

ACTUATOR SLIPS ON LIKE ORIGINAL COIL

NO PROCESS FLUID SEAL

SWIVELS

ACTUATOR REMAINS FREE TO SWIVEL ON VALVE FOR EASY CONNECTION

OPTIONAL DIFFERENTIAL PRESSURE OPERATION

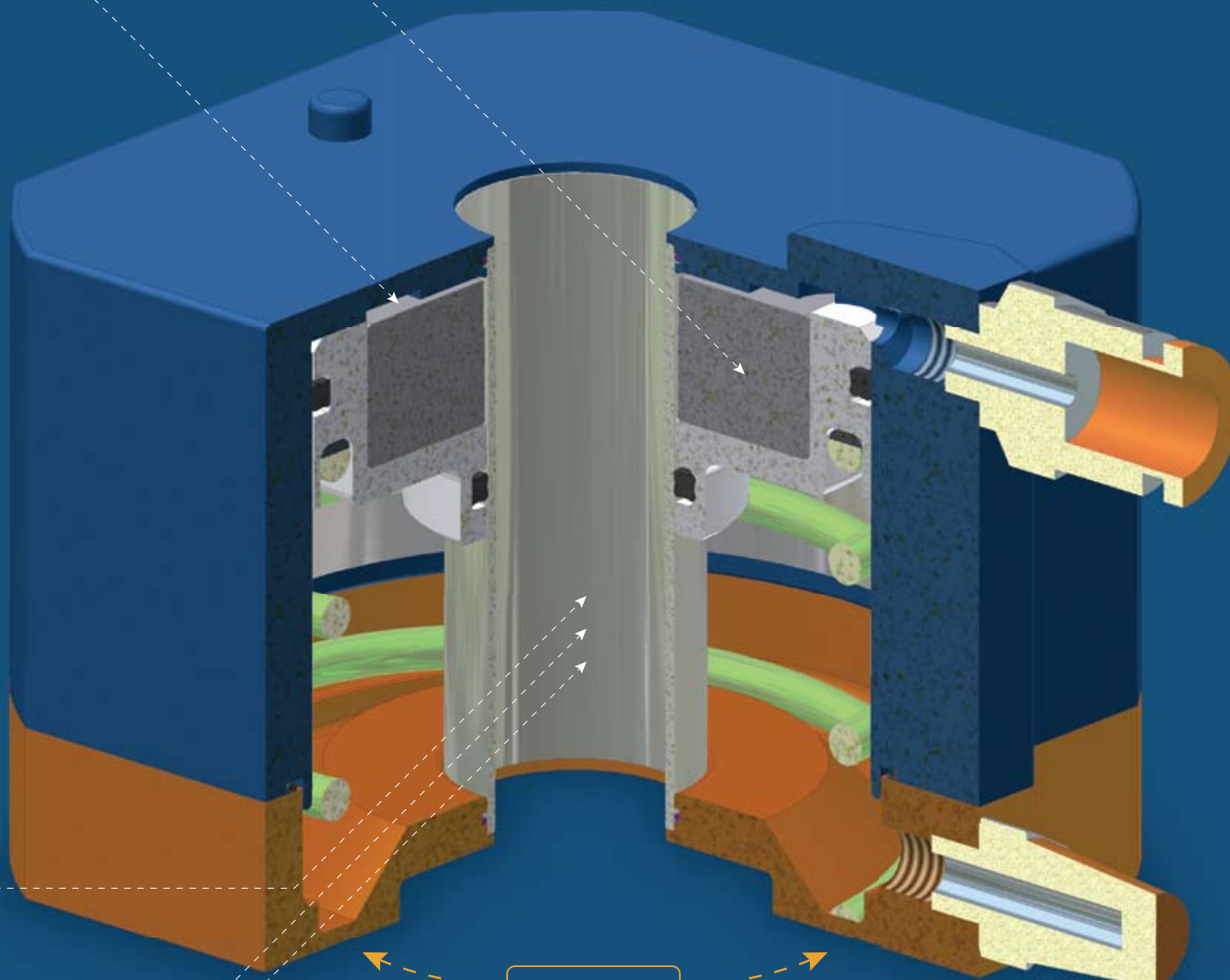

RESPONSE TIME FOR VARIOUS TUBING RUNS

5/32" TUBING ON/OFF RESPONSE TIME

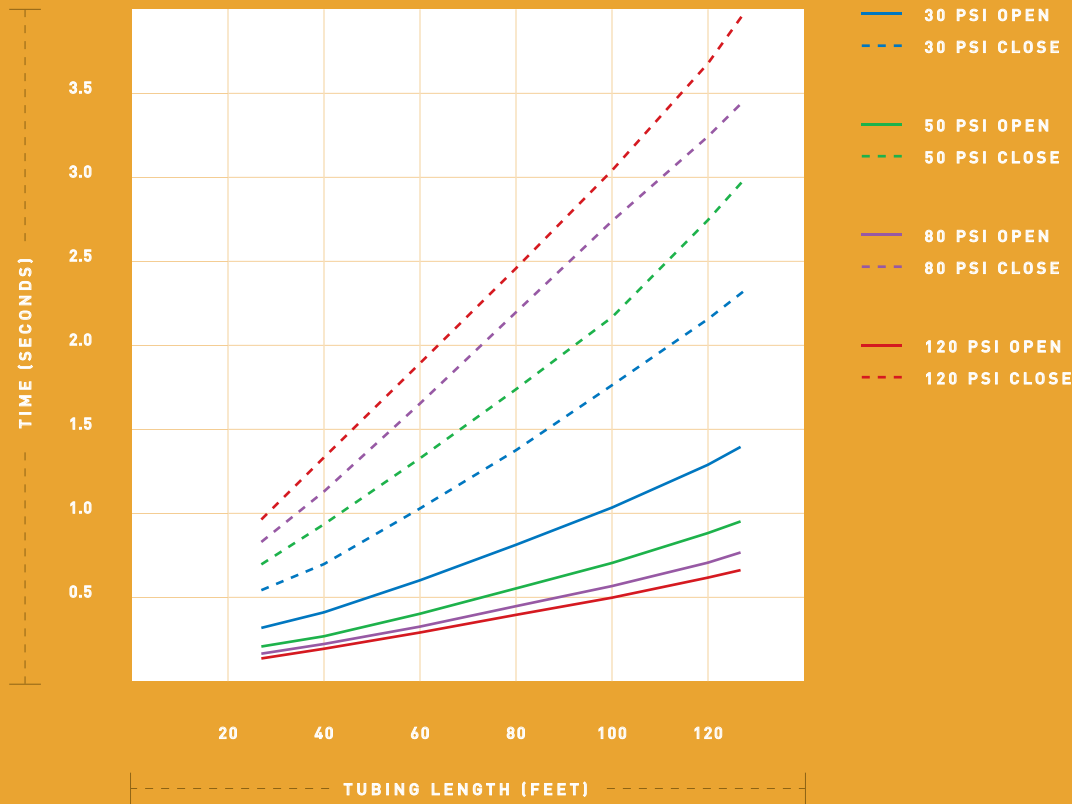

1/4" TUBING ON/OFF RESPONSE TIME

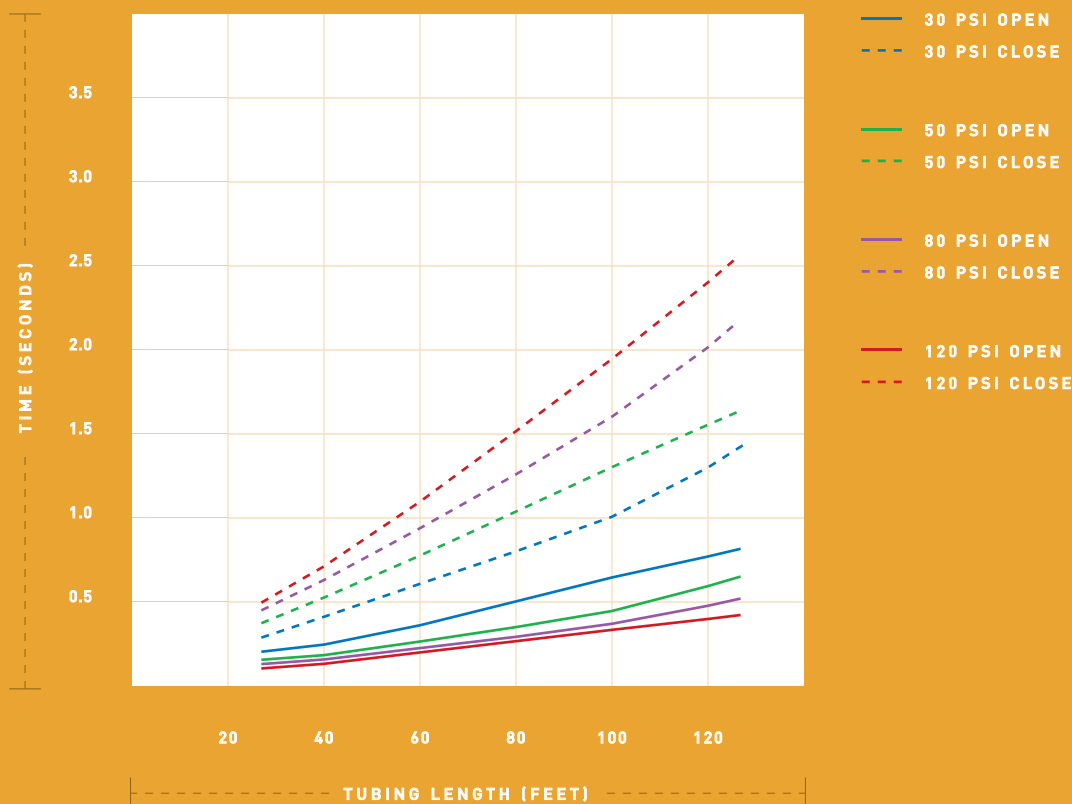

CYCLE LIFE

- > Greater than 2 million cycles

RESPONSE TIME

- > 110 msec at 80 psig; Actuator only, no tubing

CYCLE RATE

- > Continuous duty cycle, limited only by valve

ACTUATOR VOLUME

- > 27.37 ml

OPERATING CONDITIONS

- > Maximum Operating Pressure: 150 psig
- > Maximum Operating Temperature: 185 °F
- > Air Quality: clean, dry air; 40 micron filtration
- > Air Lube: not required

OPTIONS

- > Quick Release actuator retainer included.
- > Clean fluids other than air may be used, consult PneuMagnetic.
- > Can be operated submerged and in non-corrosive gas environments, as well as partial vacuum.
- > Can be operated with a hand pump.

SAFETY

- > Do NOT Dismantle. Contains powerful magnetic materials and spring under compression.
- > Do NOT Overpressurize.
- > Do NOT Exceed temperature rating.

Use caution when working with compressed air. Only qualified personnel should specify, apply, install, maintain, and troubleshoot pneumatic equipment.

As with all technical products, the safe application of the PneuMagnetic actuator depends on the system application. The system designer must assure the safe application of this product.

Copyright © 2008 PneuMagnetic, LLC. All rights reserved.

SO INGENIOUS, YOU'LL WONDER WHAT
TOOK SO LONG. *CALL NOW...*

PNEUMAGNETIC, LLC / P.O. BOX 701 / QUAKERTOWN, PA 18951

PHONE > 215.536.6262 / INFO@PNEUMAGNETIC.COM / PNEUMAGNETIC.COM

Pneu **M**agnetic